

# Hulk 1500

Ref: HULK1500

## SISTEMA DE APERTURA PARA PUERTA ENROLLABLE ROLL - UP DOOR OPENING SYSTEM

**3 years**  
limited warranty  
años de garantía limitada



SISTEMA DE APERTURA PARA CORTINAS ENROLLABLES ROLL - UP DOOR OPENING SYSTEM

Peso máximo puerta

**1500 Kg**

Max door weight 3.300 lbs

### Información técnica / Technical data

Alimentación Input voltage	220V - 60Hz (1Ph)
Alimentación motor Working voltage	AC
Max. fuerza de tracción Max. tractive force	1.617 N
Potencia Power	1.600W
Max. peso puerta (balanceada) Max. door weight (balanced)	1.500Kg (3.300 lbs)
Velocidad de apertura / cerrado Opening/closing speed	3.3 Rpm
Altura de elevación máx. maximum lifting height	9m
Tiempo de trabajo working time	7 min
Clase de aislamiento Insulation class	B
Temperatura de trabajo working temperature	-15° to 45°

### Características / Characteristics

- Metallic gears**  
Engranajes metálicos
- Sin necesidad de resortes**  
No springs needed
- Alambre del motor 100% de cobre**  
100% copper wire motor
- Alimentación de 220V - 60Hz**  
220V - 60Hz input
- Final de carrera por micro - switch**  
Micro - switch limit switch

### Incluye / Included



Botonera de 3 pasos  
3 - step button panel



Banderola con reducción por cadenas  
Chain reduction base

### Tecnologías / Technologies

- access gear**  
Engranajes metálicos  
Metallic gears
- access rescuo**  
Sistema patentado contra ruptura de cadena  
Patented anti break chain system
- access swift**  
Mayor velocidad de apertura  
Higher opening speed
- access dual-limit**  
Sistema de doble switch, mejor precisión en los límites de carrera.  
Double switch system, better precision in limits switch
- access Hemotor**  
Motor 100% en cobre, soporta hasta 120°C de temperatura  
100% copper motor, withstands up to 120°C temperature

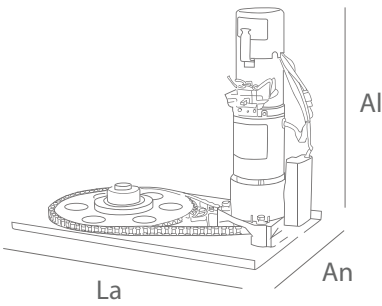

### MEDIDAS PRODUCTO / PRODUCT SIZE

LARGO (Length)	ANCHO (Width)	ALTO (Height)	PESO (Weight)
58.0 cm (1 ft - 10.8 in)	47.0 cm (1 ft - 6.5 in)	48.0 cm (1 ft - 6.8 in)	55.0 Kg (121 lbs)

### Datos logísticos / Logistic data



0679043472893

#### MEDIDAS CAJA / BOX SIZE

x1PCS/Código x 1Und

LARGO (Length)	ANCHO (Width)	ALTO (Height)	PESO (Weight)
55.0 cm (1 ft - 9.6 in)	27.0 cm (10.6 in)	30.0 cm (11.8 in)	27.4 Kg (60 lbs)



0679043472909

#### MEDIDAS CAJA / BOX SIZE

x1PCS/Código x 1Und (HULK1500 - BASE A Rodamiento y soporte lateral)

LARGO (Length)	ANCHO (Width)	ALTO (Height)	PESO (Weight)
58.0 cm (1 ft - 10.8 in)	47.0 cm (1 ft - 6.5 in)	11.0 cm (4.3 in)	28.2 Kg (62 lbs)

CONOCE MÁS



TOUCH OR SCAN



0679043472916

#### MEDIDAS CAJA / BOX SIZE

x1PCS/Código x 1Und (HULK1500 - BASE B Banderola y engranaje)

LARGO (Length)	ANCHO (Width)	ALTO (Height)	PESO (Weight)
60.0 cm (1 ft - 11.6 in)	26.0 cm (10.2 in)	16.0 cm (6.2 in)	20.6 Kg (45 lbs)